

## Belt fasteners

Bechtel also supplies the necessary belt fasteners for the assembly of the elevator belts. In various different versions, suitable for all kinds of belts.

### Belt fastener models 1, 2 and 3

Parameters models 1, 2 and 3 (in mm)

	A	B	max. belt load
Model 1	62	32	400 kg/cm
Model 2	68	32	800 kg/cm
Model 3	68	32	1.250 kg/cm

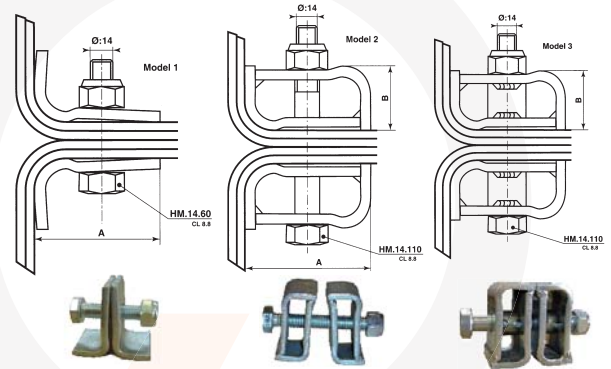

### Belt fasteners, Speedy model

3-part belt fastener made of cast iron or bronze, standard width 50 mm, suitable for maximum belt loads of 800 kg/cm.



Speedy type belt fasteners

### Assembly

Example of the assembly of 4 belt fasteners for belt widths between 200 and 230 mm. The distance between the belt fasteners may be somewhere between 0 and 10 mm.

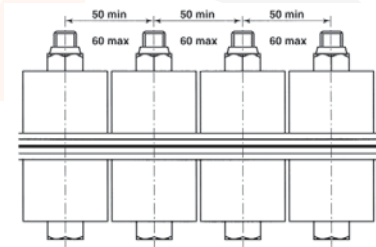

### Belt clamps

Belt clamps offer an alternative to the belt fasteners. They are manufactured to your specifications. Two models are available.

#### Model A:

For light to average applications.

#### Model B:

Belt clamps with a wedge-shaped adaptor to guide the belt over the pulley in conjunction with more demanding applications.

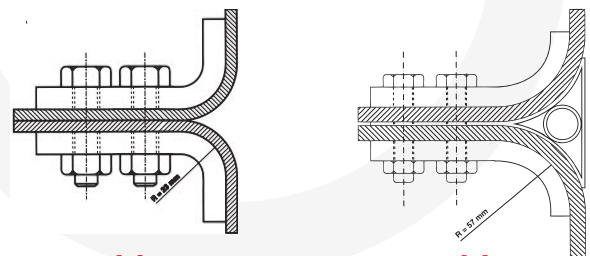

Model A

Model B

